

LED HIGH BAY

CR2000-130W L+



Factory Warehouse Library Gymnasium

- LED replacement for MH 400 W with 68% electricity saving
- High luminous efficacy (120 lm/W)
- Easy and convenient to install with E39/E40 socket base
- Various lens options to achieve the optimal illumination
- Glare prevention and beautiful interior decoration with clear shade
- Superb heat dissipation through ICEPIPE FDP Technology
- Good uniformity and flicker-free provides comfortable light
- Ensured safety with a durable surge protector
- Ultraviolet free, no mercury and lead-free RoHS Compliance



SPECIFICATION

ELECTRICAL

Wattage	130 W
Power Input	AC 100 - 277 V
Frequency	50/60 Hz
Power Factor (PF)	> 0.96
THD	< 15%
Protection Circuit	4 kV

CONSTRUCTION

Size	ø 276 x 170 mm
Weight	1.8 kg
Material	Polycarbonate, ABS
Heatsink	Copper ICEPIPE Heatsink
Operating Temperature	-30°C ~ 50°C (-22°F ~ 122°F)
Installation Angle	0°

OPTICS

Lumen output	15,600 lm
Efficacy	120 lm/W
Replacement	MH 400 W
CCT	5,700 K
LED Package Life time	50,000 hours (25°C) *LED package life time according to industry standard (LM80). *High operating temperature may shorten life span of LED package and LED lamp.
CRI	82 Ra
Beam Angle	90°

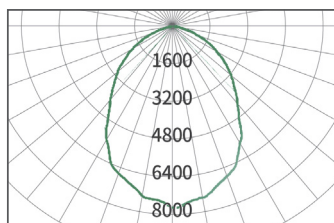

WHY ICEPIPE

Ultra-Light & Retrofit High Bay

UR2050 became even easier to install, thanks to the breakthrough in design that guarantees its dramatically compact retrofit fixture of 1.3 kg (2.9 lbs). Just simply insert it into the existing sockets and turn firmly for installation.

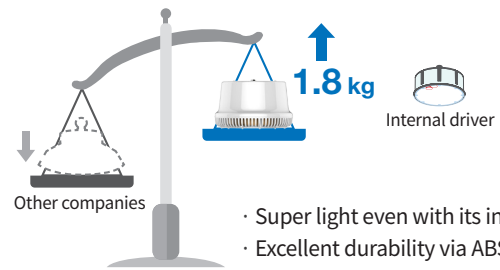

- Super light even with its internal driver
- Excellent durability via ABS housing
- Easy to install

Highly Efficient ICEPIPE heatsink

ICEPIPE heatsink was created by our patented Fluid Dynamic Pressure Technology, which enables heat dissipation 200 times faster (40,000 W/m·K) than that of conventional aluminum (Al) heatsink. Liquid circulation takes place inside the pipe, traveling through the coil and cooling down heat from the LEDs in the most efficient way.

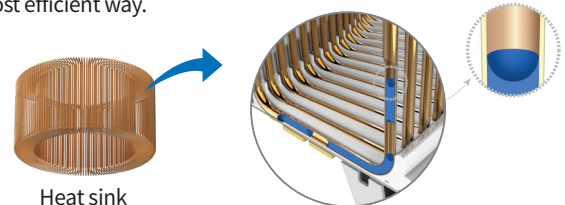

- The fastest heat transfer rate
- Efficient air flow
- Uses light weight copper



INSTALLATION

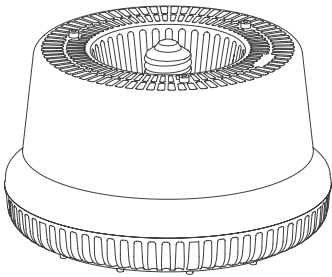

STEP 1

Turn off the power before installation.
Remove the old ballast, capacitor and ignitor (if existing)

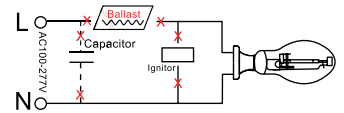

STEP 2

Make sure the alternating current wires are connected to the E39/40 socket directly.
(Reattach or replace ground lead if needed.)

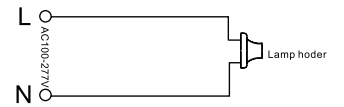

STEP 3

Fix the LED into the corresponding socket.

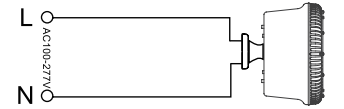

COVER OPTIONS

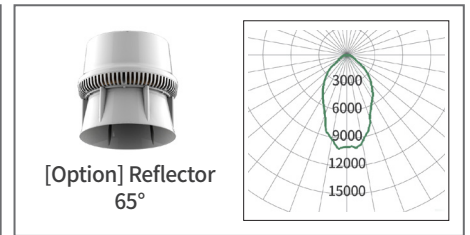
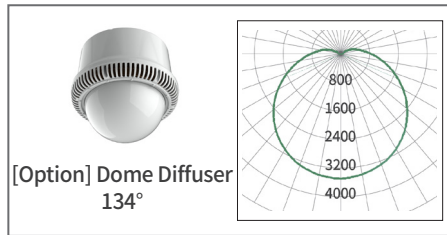
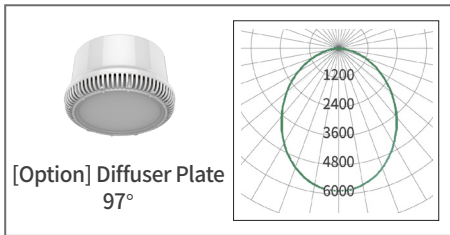

PACKING

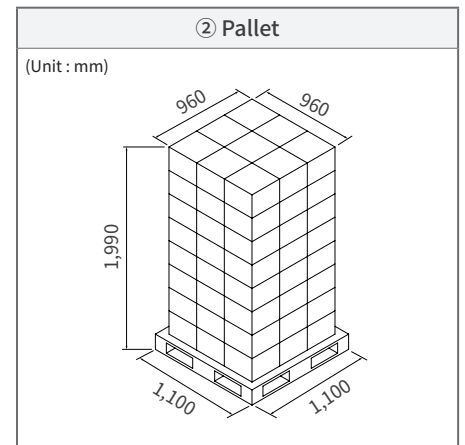
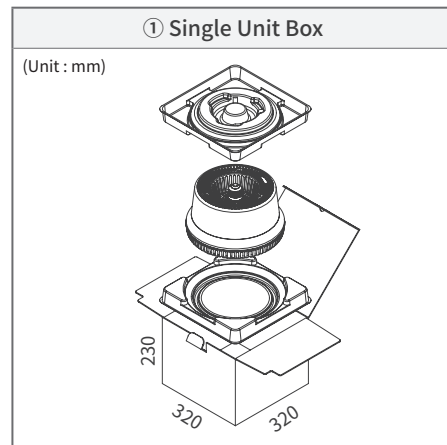
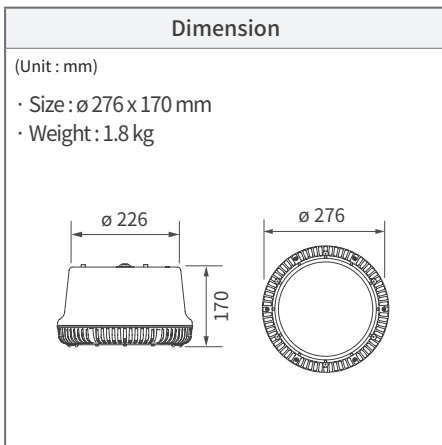

Type	① Single Unit Box	② Pallet	20ft Container-Palletized	Remarks
Quantity	1	72	720 (10 Pallets)	3R x 3R x 8L = 72 (pcs)
Dimension(mm)	320 x 320 x 230	1,100 x 1,100 x 1,990	5,500 x 2,200 x 1,990	
GWT(kg)	2.62	206	2,060	
CBM	0.023	2.41	24.10	

⚠ WARNINGS

- Do not use with direct current and ballast.
- This lamp is non-dimmable, do not connect with dimmer
- This lamp must be installed straight downward and cannot be installed in different orientation.
- Do not install the lamp in an enclosed space.
- Do not install on any other shade that is not provided by ICEPIPE.
- Please read the instruction manual carefully before installation.



* Please refer to our full warranty terms and contact your sales representative for details.

