

LED FLOOD LIGHT HB2010-60S

CE CB

- Convenient maintenance with external driver
- Clamping Technology applied LED flood light
- High luminous efficacy (150 lm/w)
- LED replacement for MH 200 W with 68% electricity saving
- Various cover options and mounting options are available
- Various beam angle are available with cover lens
- [Option] Dimming : 3 in 1 Dimming Control (0-10V, PWM, Resistance)
- Ultraviolet free, no mercury and lead-free RoHS Compliance



SPECIFICATION

ELECTRICAL

Wattage	60 W
Power Input	AC 100 - 240 V
Frequency	50/60 Hz
Power Factor (PF)	> 0.9
THD	< 20%
Protection Circuit	2 kV(L-N), 4kV(Line-FG)

CONSTRUCTION

Size	ø 276 x 264 mm
Weight	3.2 kg
Material	Polycarbonate, STS
Heatsink	Copper ICEPIPE Heatsink
IP Rating	IP66
Operating Temperature	-30°C ~ 50°C (-22°F ~ 122°F)
Installation Angle	360°

OPTICS

Lumen output	9,000 lm
Efficacy	150 lm/W
Replacement	MH 200 W
CCT	5,700 K
LED Package Life time	50,000 hours (25°C) *LED package life time according to industry standard (LM80). *High operating temperature may shorten life span of LED package and LED lamp.
CRI	80 Ra
Beam Angle	80°

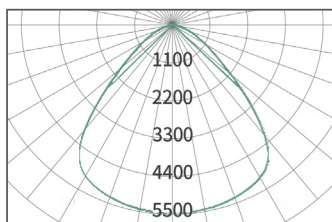

ICEPIPE HEATSINK

Highly Efficient ICEPIPE heatsink

ICEPIPE heatsink was created by our patented Fluid Dynamic Pressure Technology, which enables heat dissipation 200 times faster (40,000 W/m·K) than that of conventional aluminum (Al) heatsink. Liquid circulation takes place inside the pipe, traveling through the coil and cooling down heat from the LEDs in the most efficient way.

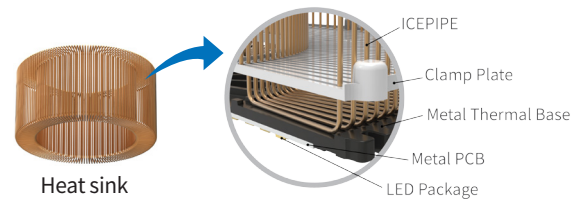

- The fastest heat transfer rate
- Efficient air flow
- Uses light weight copper

APPLICATION



Factory

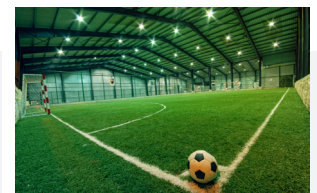

Gymnasium





Auditorium



Warehouse

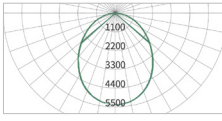
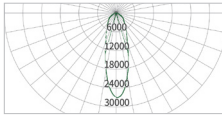
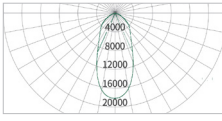

COVER OPTIONS

Cover			
	Diffuser Cover	Cover Lens	Reflector
LIGHT DISTRIBUTION CURVE			
Beam Angle	97°	35°	65°

INSTALLATION TYPE

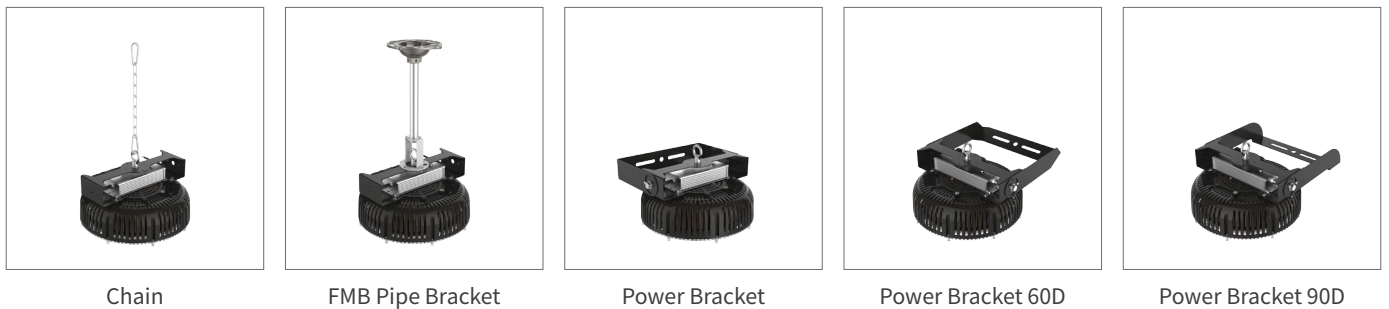

PACKING

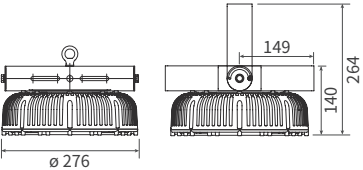
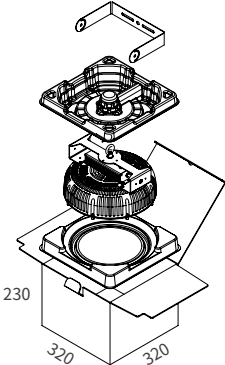
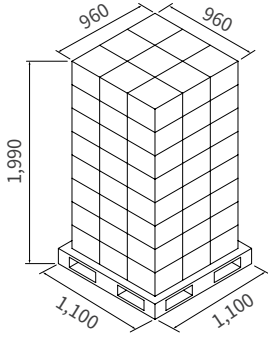
<p>Dimension</p> <p>(Unit : mm)</p> <ul style="list-style-type: none"> Size : $\varnothing 276 \times 264$ mm Weight : 3.2 kg 	<p>① Single Unit Box</p> <p>(Unit : mm)</p> 	<p>② Pallet</p> <p>(Unit : mm)</p> 
---	--	---

Type	① Single Unit Box	② Pallet	20ft Container-Palletized	Remarks
Quantity	1	72	720 (10 Pallets)	3R x 3R x 8L = 72 pcs
Dimension(mm)	320 x 320 x 230	1,100 x 1,100 x 1,990	5,500 x 2,200 x 1,990	
GWT(kg)	3.75	287	2,870	
CBM	0.023	2.36	23.60	

WARNINGS

- Do not use with direct current and ballast.
- Do not install the lamp in an enclosed place.
- Do not install on any other shade that is not provided by ICEPIPE.
- Please follow the recommended daily operating hours.
- Please read the instruction manual carefully before installation.



* Please refer to our full warranty terms and contact your sales representative for details.

