

# LED FLOOD LIGHT HB2200-150S



- Clamping Technology applied LED flood light
- High luminous efficacy (150 lm/w)
- LED replacement for MH 500 W with 70% electricity saving
- Installable vertically and horizontally at any angle
- Various cover options and mounting options are available
- Various beam angle are available with cover lens
- Ultraviolet free, no mercury and lead-free RoHS Compliance



## SPECIFICATION

### ELECTRICAL

Wattage	150 W
Power Input	AC 120 - 277 V
Frequency	50/60 Hz
Power Factor (PF)	> 0.96
THD	< 15%
Protection Circuit	4 kV

### CONSTRUCTION

Size	ø 276 x 277 mm
Weight	3.3 kg
Material	Polycarbonate, STS
Heatsink	Copper ICEPIPE Heatsink
IP Rating	IP66
Operating Temperature	-30°C ~ 50°C (-22°F ~ 122°F)
Installation Angle	360°

### OPTICS

Lumen output	22,500 lm
Efficacy	150 lm/W
Replacement	MH 500 W
CCT	5,700 K
LED Package Life time	50,000 hours (25°C) <small>*LED package life time according to industry standard (LM80). *High operating temperature may shorten life span of LED package and LED lamp.</small>
CRI	80 Ra
Beam Angle	80°

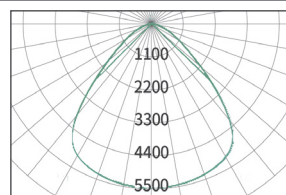

## ICEPIPE HEATSINK

### Highly Efficient ICEPIPE heatsink

ICEPIPE heatsink was created by our patented Fluid Dynamic Pressure Technology, which enables heat dissipation 200 times faster (40,000 W/m·K) than that of conventional aluminum (Al) heatsink. Liquid circulation takes place inside the pipe, traveling through the coil and cooling down heat from the LEDs in the most efficient way.

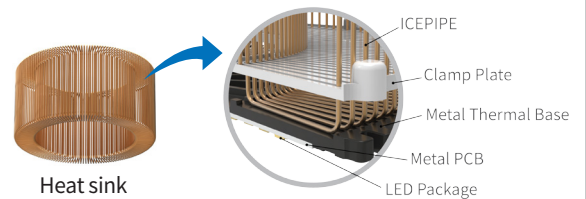

- The fastest heat transfer rate
- Efficient air flow
- Uses light weight copper

## APPLICATION



Swimming Pool



Outdoor Sports Facilities





Building Exterior



Factory

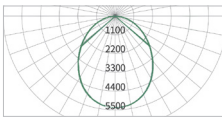
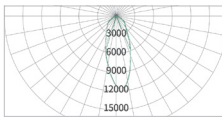
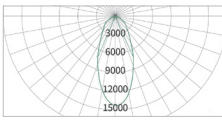
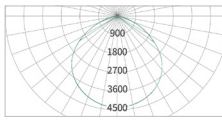
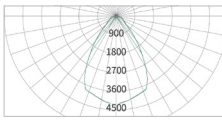

## COVER OPTIONS

Cover					
	Diffuser Cover	Cover Lens			Reflector
LIGHT DISTRIBUTION CURVE					
Beam Angle	97°	45°	60°	110°	65°

## INSTALLATION TYPE



Chain



FMB Pipe Bracket



GS Bracket



Hinge Bracket



60D Hinge Bracket



90D Hinge Bracket

## PACKING

Type	Single Unit Box	Pallet	20ft Container-Palletized	Remarks
Quantity	1	72	720 (10 Pallets)	3R x 3R x 8L = 72 (pcs)
Dimension(mm)	320 x 320 x 230	1,100 x 1,100 x 1,990	5,500 x 2,200 x 1,990	
GWT(kg)	2.85	231	2,310	
CBM	0.023	2.36	23.60	

### ⚠ WARNINGS

- Do not use with direct current and ballast.
- Do not install the lamp in an enclosed place.
- Do not install on any other shade that is not provided by ICEPIPE.
- Please follow the recommended daily operating hours.
- Please read the instruction manual carefully before installation.



\* Please refer to our full warranty terms and contact your sales representative for details.

