

HB2010

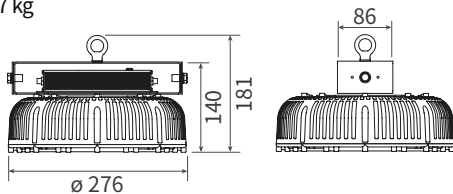

DIMENSION

- Size : $\phi 276 \times 181$ mm
- Weight : 2.7 kg



FEATURES

- Convenient maintenance with external driver
- Clamping Technology applied LED high bay
- High luminous efficacy (150 lm/W)
- LED replacement for MH 200~350 W with 75% electricity saving
- Various cover options and mounting options are available
- Various beam angle are available with cover lens
- Ultraviolet free, no mercury and lead-free RoHS Compliance

SPECIFICATION

Model No.	Wattage	Replacement	Luminous Efficacy	Total Lumen	CRI	CCT	Voltage	Frequency	Surge withstand capability
HB2010-60S	60 W	MH 200 W	150 lm/W	9,000 lm	80 Ra	5,700 K	AC 100-240 V	50/60 Hz	L-N 4kV L-FG 6kV
HB2010-80S	80 W	MH 250 W	150 lm/W	12,000 lm	80 Ra	5,700 K	AC 220-240 V	50/60 Hz	L-N 6kV L-FG 10kV
HB2010-100S	100 W	MH 350 W	150 lm/W	15,000 lm					

- PF : > 0.96 (HB2010-60S : > 0.9)
- THD : < 15% (HB2010-60S : < 20%)
- IP Rating : -
- Material : Polycarbonate, STS
- Heatsink : Copper ICEPIPE Heatsink
- Operating Temperature : -30°C ~ 50°C (-22°F ~ 122°F)
- Installation Angle : 360°

- External Driver : 100W x 1EA (3 in 1 dimming: 0-10V/PWM/3-Timer-Modes for 60S)
- CCT : Standard - 5700 K, 3000 K / Option - 5000 K, 4000 K, 2700 K
- LED Package Life time : 50,000 hours (25°C)
- *LED package life time according to industry standard (LM80), high operating temperature may shorten life span of LED package and LED lamp.

APPLICATION



Factory



Gymnasium



Auditorium



Warehouse

HB2010 / HB2210

INSTALLATION TYPE * Illustrated by HB2010

① Chain

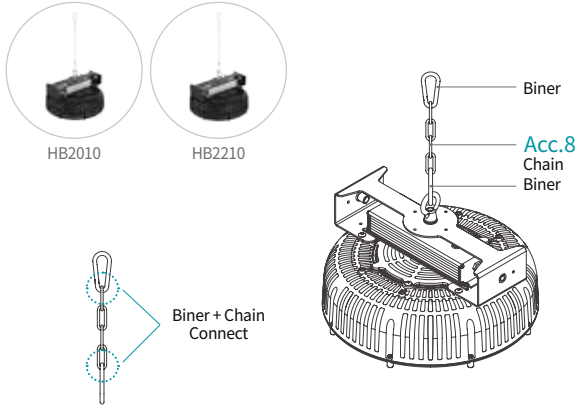

② FMB Pipe Bracket

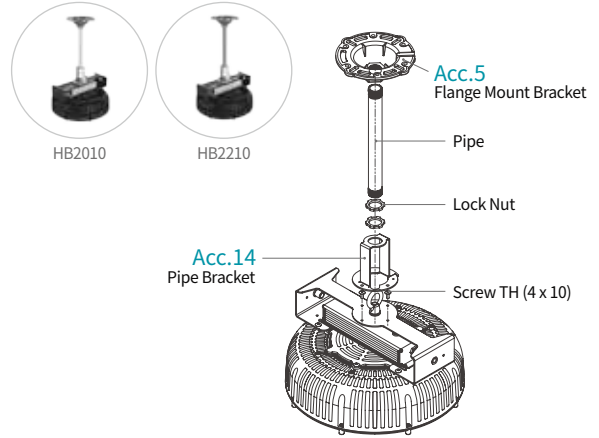

Acc.13 Dome Diffuser

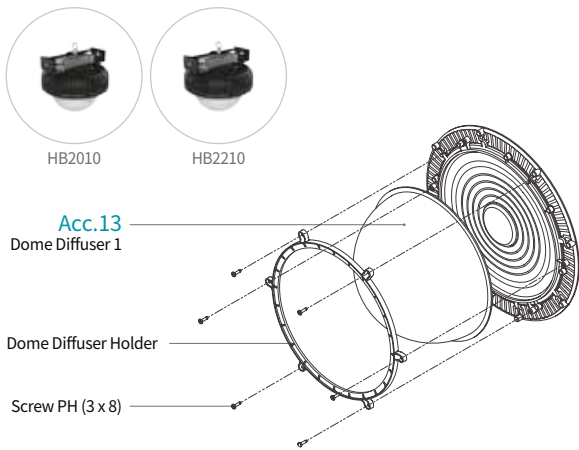

Acc.2 Reflector

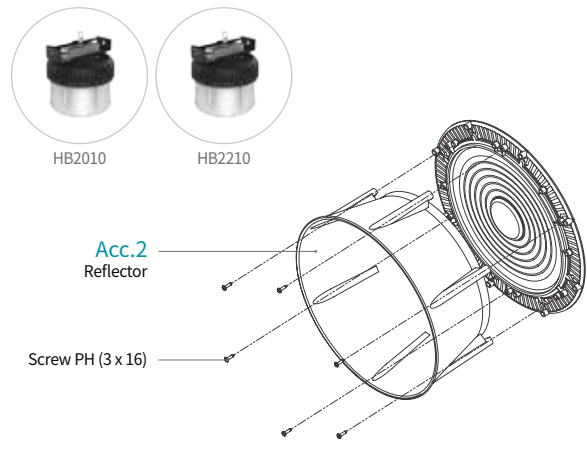

Beam Angle * Illustrated by HB2010

Standard	Clear	Diffuser Cover	Cover Lens		Dome Diffuser	Reflector
80°	97°	35°	50°	110°	130°	65°



Dimming Option



+



Dimmer



Sensor



Gateway

- 0-10V/PWM/3-Timer-Modes
- Motion/daylight sensor
- Wireless/wired control applicable

If it's not compatible dimming (0-10V, PWM, 3-timer-modes), interface controller is required.
e.g.) If it's connected with DALI/DMX, additional switching module (DALI-PWM converter) is needed.