

External Driver

130 W / 150 W

# HB2210 HB221D

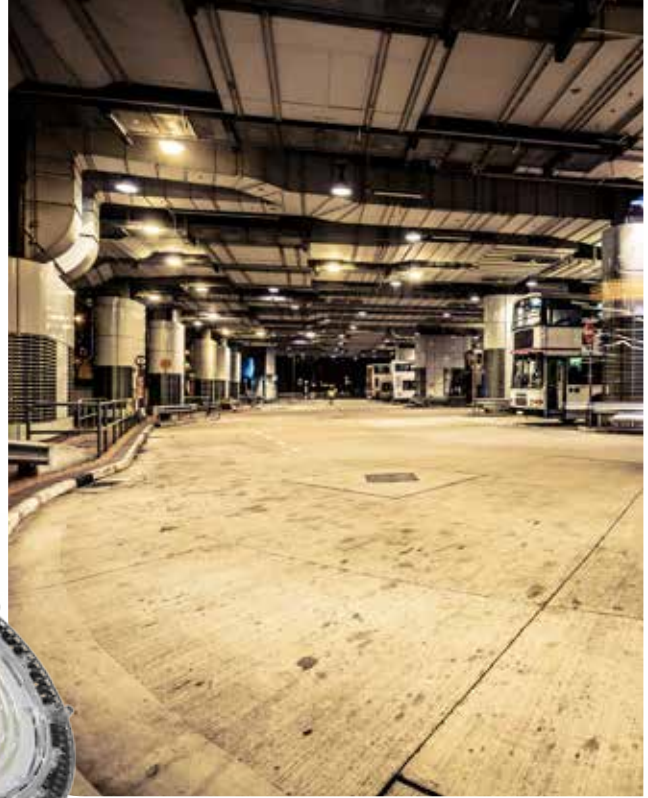

LED HIGH BAY

LED FLOOD LIGHT

LED BULB

## DIMENSION

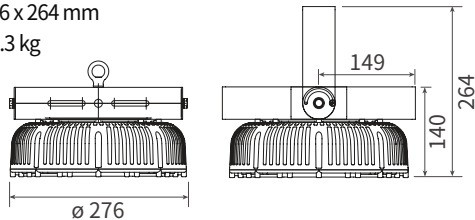

- Size :  $\varnothing 276 \times 264$  mm
- Weight : 3.3 kg



## FEATURES

- Convenient maintenance with external driver
- Clamping Technology applied LED flood light
- High luminous efficacy (150 lm/W)
- LED replacement for MH 400~500 W with 70% electricity saving
- Various cover options and mounting options are available
- Various beam angle are available with cover lens
- Ultraviolet free, no mercury and lead-free RoHS Compliance

## SPECIFICATION

Model No.	Wattage	Replacement	Luminous Efficacy	Total Lumen	CRI	CCT	Voltage	Frequency	Surge withstand capability
HB2210-130S	130 W	MH 400 W	150 lm/W	19,500 lm	80 Ra	5,700 K	AC 220-240 V	50/60 Hz	L-N 6kV L-FG 10kV
HB2210-150S	150 W	MH 500 W	150 lm/W	22,500 lm					
 HB221D-130S	130 W	MH 400 W	150 lm/W	19,500 lm	80 Ra	5,700 K	AC 100-240 V	50/60 Hz	L-N 6kV L-FG 10kV
 HB221D-150S	150 W	MH 500 W	150 lm/W	22,500 lm					

- PF : > 0.96
- THD : < 15% (HB221D : < 10%)
- IP Rating : IP66

- Material : Polycarbonate, STS
- Heatsink : Copper ICEPIPE Heatsink
- Operating Temperature : -30°C ~ 50°C (-22°F ~ 122°F)
- Installation Angle : 360°

- External Driver : 150W x 1EA (3 in 1 dimming: 0-10V/PWM/3-Timer-Modes for D-150S)
- CCT : Standard - 5700 K, 3000 K / Option - 5000 K, 4000 K, 2700 K
- LED Package Life time : 50,000 hours (25°C)

\*LED package life time according to industry standard (LM80), high operating temperature may shorten life span of LED package and LED lamp.

## APPLICATION



Outdoor Parking Lot



Outdoor Sports Facilities



Building Exterior



Gas Station

**INSTALLATION TYPE** \* Illustrated by HB221D

**① Chain**

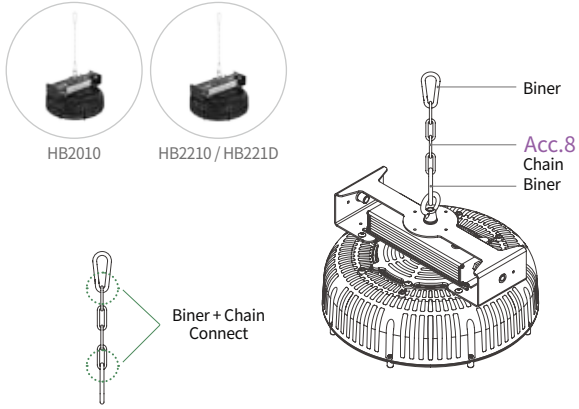

**② FMB Pipe Bracket**

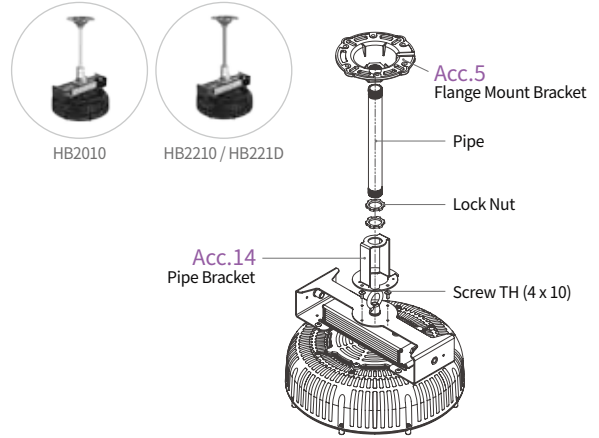

**③ Power Bracket**

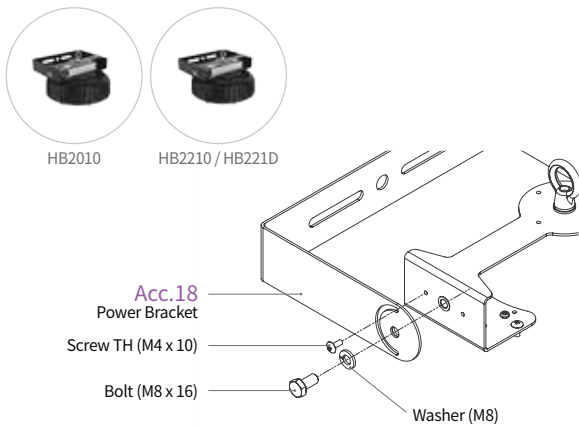

**④ Power Bracket 60D**

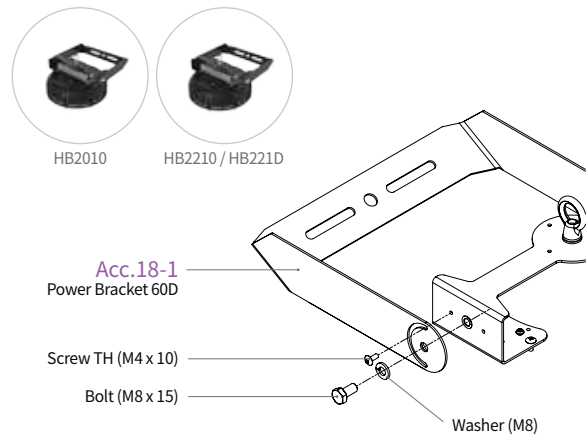

**⑤ Power Bracket 90D**

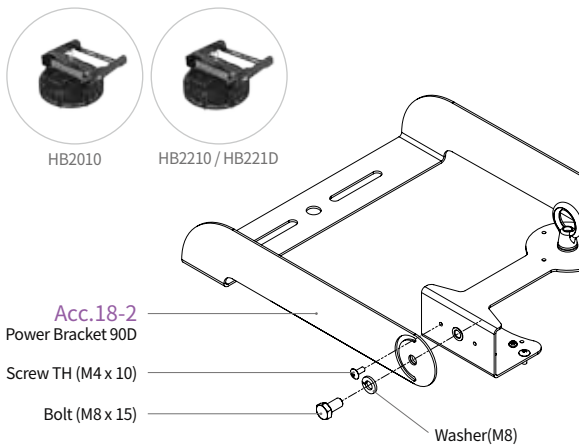

**Acc.2 Reflector**

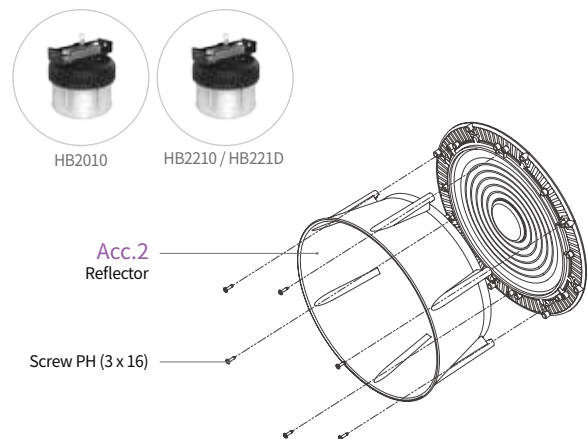



### Dimming Option

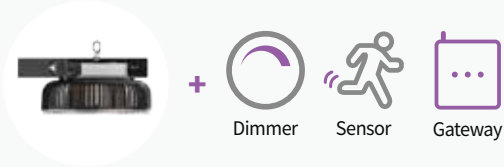

- 0-10V/PWM/3-Timer-Modes
- Motion/daylight sensor
- Wireless/wired control applicable

If it's not compatible dimming (0-10V, PWM, 3-timer-modes), interface controller is required. e.g.) If it's connected with DALI/DMX, additional switching module (DALI-PWM converter) is needed.

### Beam Angle \* Illustrated by HB2010

Standard	Clear	Diffuser Cover	Cover Lens		Reflector
	80°	97°	35°	50°	110°
					65°