



80 W / 100 W

HB2000



DIMENSION

- Size : $\varnothing 276 \times 277$ mm
- Weight : 2.7 kg

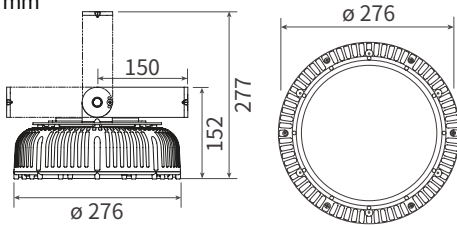

FEATURES

- Clamping Technology applied LED flood light
- High luminous efficacy (150 lm/W)
- LED replacement for MH 250~350 W with 75% electricity saving
- Installable vertically and horizontally at any angle
- Various cover options and mounting options are available
- Various beam angle are available with cover lens
- Ultraviolet free, no mercury and lead-free RoHS Compliance

SPECIFICATION

Model No.	Wattage	Replacement	Luminous Efficacy	Total Lumen	CRI	CCT	Voltage	Frequency
HB2000-80S	80 W	MH 250 W	150 lm/W	12,000 lm	80 Ra	5,700 K	AC 120-277 V	50/60 Hz
HB2000-100S	100 W	MH 350 W	150 lm/W	15,000 lm				

- PF : > 0.96
- THD : < 15 %
- Surge withstand capability : L-N 4kV, L-FG 6kV
- Operating Temperature : -30°C ~ 50°C (-22°F ~ 122°F)
- Material : Polycarbonate, STS
- Heatsink : Copper ICEPIPE Heatsink
- IP Rating : IP66
- Installation Angle : 360°
- CCT : Standard - 5700 K, 3000 K / Option - 5000 K, 4000 K, 2700 K
- LED Package Life time : 50,000 hours (25°C)
- *LED package life time according to industry standard (LM80), high operating temperature may shorten life span of LED package and LED lamp.

APPLICATION



Military Border



Outdoor Sports Facilities



Building Exterior



Gas Station



INSTALLATION TYPE * Illustrated by HB2000

① Chain

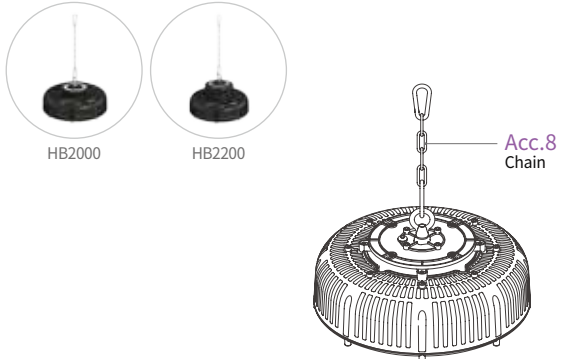

② FMB Pipe Bracket

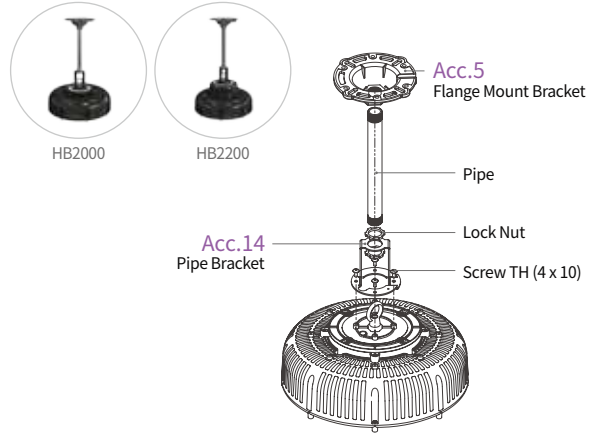

③ GS Bracket

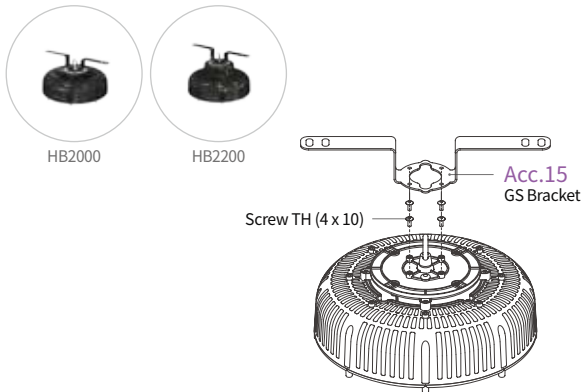

④ Hinge Bracket

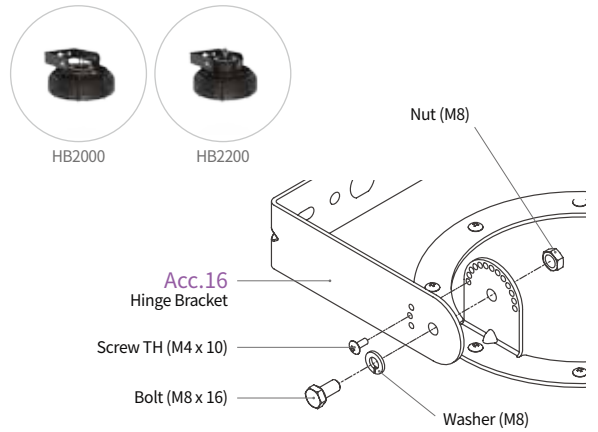

⑤ 60D Hinge Bracket

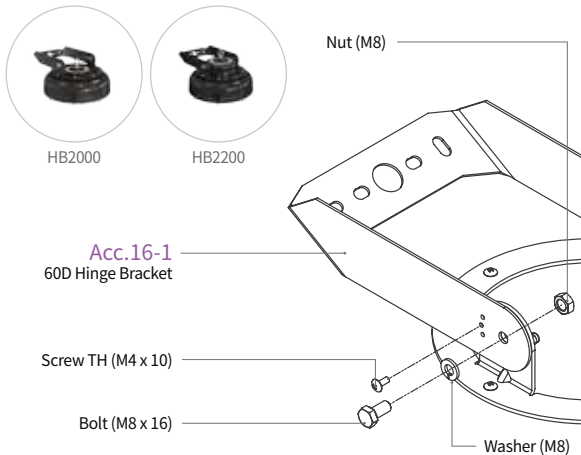

⑥ 90D Hinge Bracket

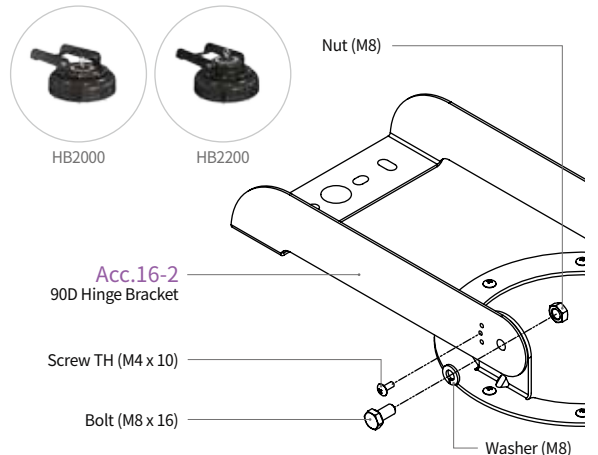

Acc.2 Reflector

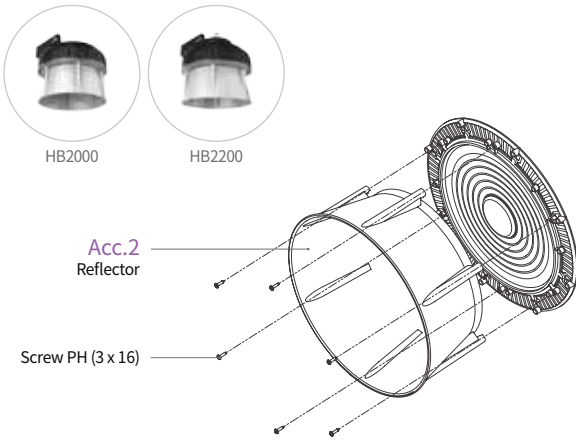

Beam Angle * Illustrated by HB2000

Standard	Clear	Diffuser Cover	Cover Lens		Reflector
80°	97°	45°	60°	110°	65°