



External Driver

400 W

# NCD



Option Sun visor



## DIMENSION

- Size :  $\phi$  388 x 248 mm
- Weight : 7.5 kg(400) / 8 kg(400C) \*SMPS incl.(1.2 kg)

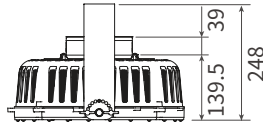
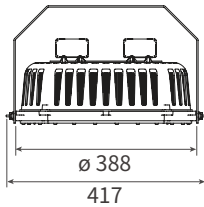

## FEATURES

- High wattage but compact size
- External driver for safe & easy repair
- Usable at indoor and outdoor with various mounting options
- Compact and versatile design with 360° installation angle
- IP66 (driver & lamp) for outdoor use
- Excellent heat dissipation by ICEPIPE FDP technology
- Eco-friendly & RoHS compliant (UV/Lead/Mercury-free)

## SPECIFICATION

Model No.	Wattage	Replacement	Luminous Efficacy	Total Lumen	CRI	CCT	Voltage	Frequency
NCD-400	400 W	MH 1 kW	140 lm/W	56,000 lm	> 80 Ra	5,700 K	AC 220 V	50/60 Hz
NCD-400C	400 W	MH 1 kW	150 lm/W	60,000 lm	> 75 Ra			

- PF : > 0.95
- THD : < 15 %
- Surge withstand capability : L-N 4kV, L-FG 2kV
- IP Rating : IP66
- Material : Polycarbonate, aluminum, Steel
- Heatsink : Copper ICEPIPE Heatsink
- Operating Temperature : -30°C ~ 50°C
- Installation Angle : 360°
- CCT : 5700 K
- LED Package Life time : 50,000 hours (25°C)
- \*LED package life time according to industry standard (LM80), high operating temperature may shorten life span of LED package and LED lamp

## APPLICATION



Indoor Sports Facilities

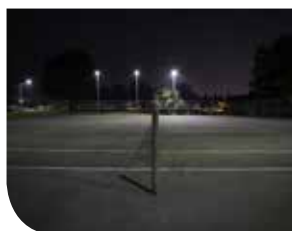

Outdoor Sports Facilities



Building Exterior



Outdoor Parking Lot

## INSTALLATION TYPE

### ① Multi Hanger

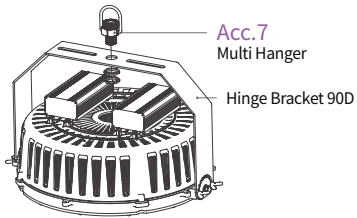

### ② Chain

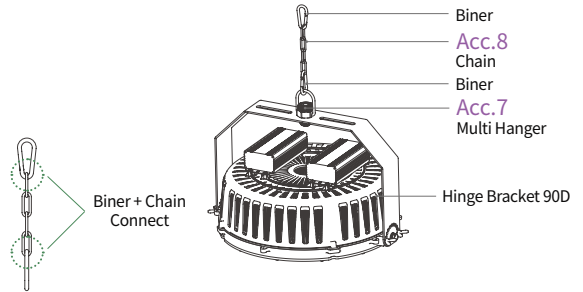

### ③ Pipe

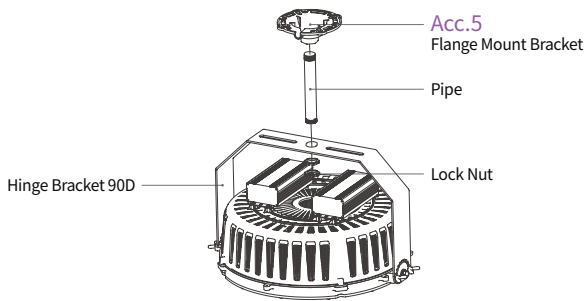

### ④ Hinge Bracket 45D

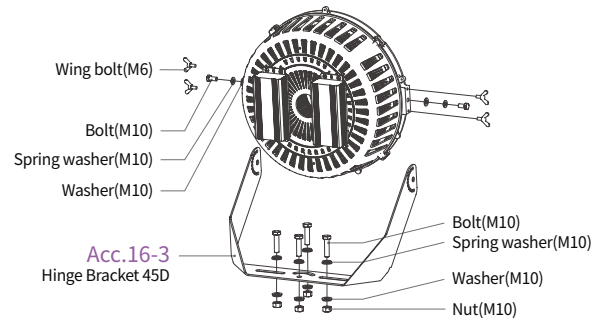

### ⑤ (STANDARD) Hinge Bracket 90D

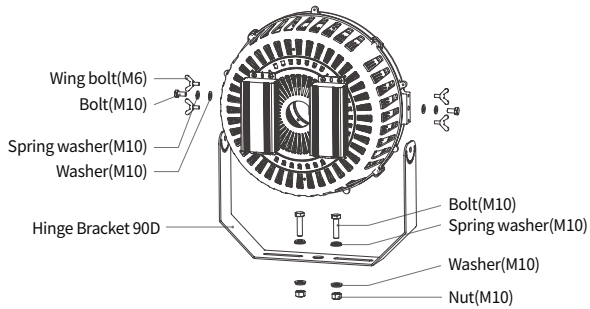

### Acc.22 Sun visor

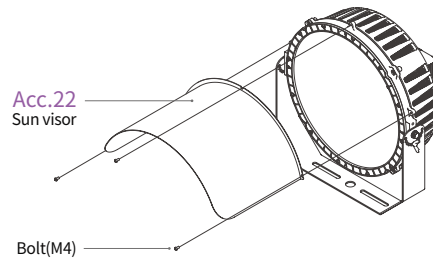

## Beam Angle

NCD-400	NCD-400C				
110°	20°	30°	45°	60°	